



Multi-Position Air Handler

Model:

**BLD, BLN, BL*C
SLN, SLNW,
SLNCW**



Features:

- Multi-Position Up-Flow and Horizontal (Units comes Up-Flow, Horizontal Left or Horizontal Right)
(Field convertible to the opposite Horizontal direction)

- Polymer drain pan
- Attractive, powder painted exterior
- Fully insulated cabinet
- 208/ 230 VAC operation
- Multi-Speed Direct Drive Blower
- SL* air flow from 600 to 1600 CFM
- BL* air flow from 1200 to 2000 CFM
- A1L/A2L COMPLIANT

Optional Features:

- Factory installed Thermal Expansion Valve
- Optional factory installed Electric Heat
- 3, 5, 6, 8, 10, 15, or 20 kW
- Electrical Disconnect is standard with 15 and 20 kW heaters
- Slide in Long Life Aluminum or Copper DX Coils available
- Field installed Heat kits available from 3 kW - 20 kW
- ECM Motor



MULTI - POSITION AIR HANDLERS SERIES

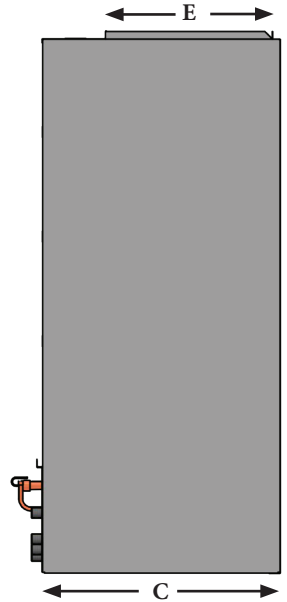
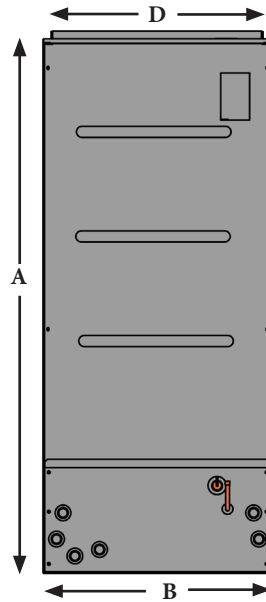
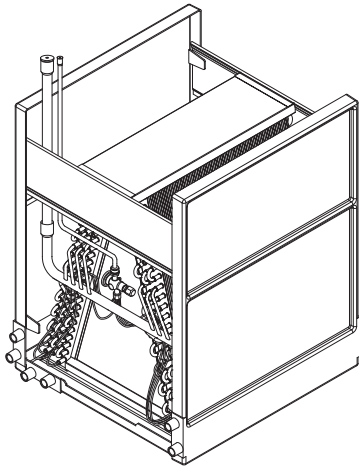

Cabinet Dimensions					
Model	Cabinet Height	Cabinet Width	Cabinet Depth	Supply Width	Supply Depth
SLN 18 - 36	48.00"	20.50"	22.00"	19.00"	16.00"
BLT 36 - 60	56.00"	21.50"	23.00"	20.00"	19.00"
BLN 36 - 60	54.00"	21.50"	26.50"	20.00"	19.25"

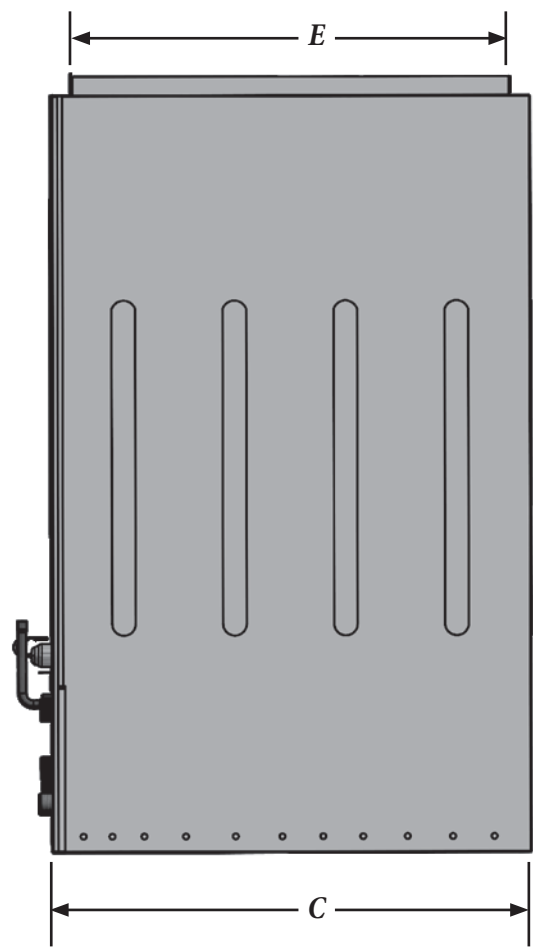
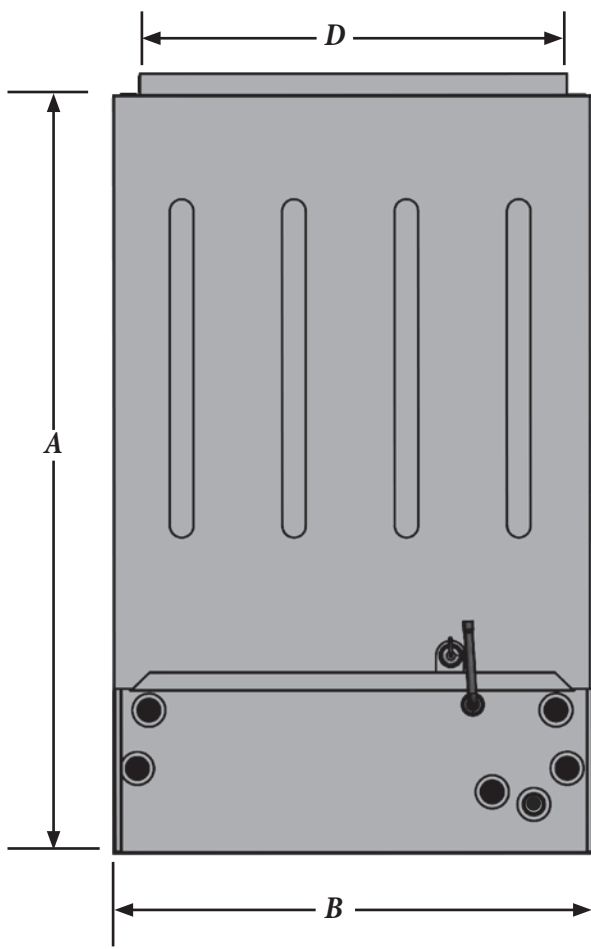

Cabinet Code	Cabinet Height - A				Cabinet Width Front - B	Cabinet Width Back	Cabinet Depth C	Opening Width D	Opening Depth E
	Coils 14" - 18"	Coils 20" - 24"	Coils 26" - 28"	Coils 30" - 32"					
ASQN - 5	26.50"	---	---	---	14.50"	15.50"	21.50"	13.00"	20.25"
ASQN - 6	26.50"	28.75"	32.625"	37.75"	16.50"	17.50"	21.50"	15.00"	20.25"
ASQN - 7	26.50"	28.75"	32.625"	37.75"	17.50"	18.50"	21.50"	16.00"	20.25"
ASQN - 7D	26.50"	28.75"	32.625"	37.75"	17.50"	18.50"	23.75"	16.00"	22.25"
ASQN - 8	26.50"	28.75"	32.625"	37.75"	20.50"	21.50"	21.50"	19.00"	20.25"
ASQN - 8D	26.50"	28.75"	32.625"	37.75"	20.50"	21.50"	23.75"	19.00"	22.25"
ASQN - 9	26.50"	28.75"	32.625"	37.75"	24.50"	25.50"	21.50"	23.00"	20.25"
ASQN - 9D	---	28.75"	32.625"	37.75"	24.50"	25.50"	23.75"	23.00"	22.25"

- Specify *StyleQuest* Cabinet When Ordering (ASQN)
- Specify *Right* or *Left* Drain Pan and Refrigerant
- *5 Cabinet accommodates (1) Horizontal drain pan ONLY (RH or LH)
- **6 - 9D Cabinet accommodates (2) Horizontal drain pans, if desired

- ***For a **Single** Drain Pan, Place a "Q1" before the Cabinet Code
- ***For **Two** Drain Pans, Place a "Q2" before the Cabinet Code
- Specifications May Change Without Notice

SLN Designed for 1.5 to 3 Tons

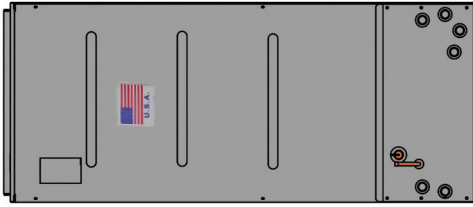

Horizontal Left

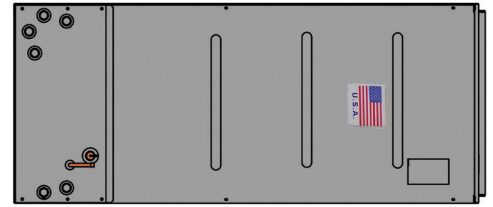

Horizontal Right

A single or multi-family air handler designed to be installed in a vertical, left or right horizontal position. A patent product that has three durable drain pans that allows the unit to be installed left, right, or in the up-flow position, without switching a single drain pan. It's compact design fits through most attic stairways and small closets for an easy installation.

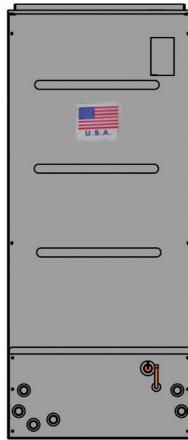

Up-Flow

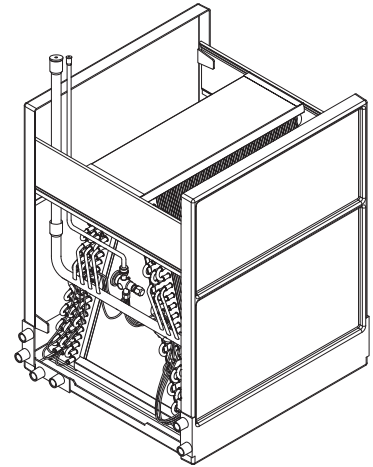

SLN Recommended Coil Sizes		
Air Handler		Tonnage
14 SEER Air Handler with Coil		
SLN18-A2886G	14 SEER	1.5
SLN24-A2086G	14 SEER	2
SLN30-A3886G	14 SEER	2.5
SLN36-A3086G	14 SEER	3
Replacement Non-Rated SLN Air Handler with Coil		
SLN18-A2884G	Non-Rated	1.5
SLN24-A2084G	Non-Rated	2
SLN30-A3882G	Non-Rated	2.5
SLN36-A3Y84G	Non-Rated	3
<i>Freight Included on Pricing for Truckload Quantities</i>		

BLN Designed for 3 to 5 Tons

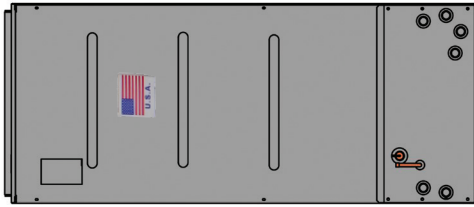

Horizontal Left

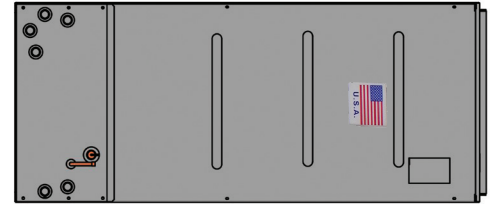

Horizontal Right

A single or multi-family air handler designed to be installed in a vertical, left or right horizontal position. A patent product that has three durable drain pans that allows the unit to be installed left, right, or in the up-flow position, without switching a single drain pan. It's compact design fits through most attic stairways and small closets for an easy installation.

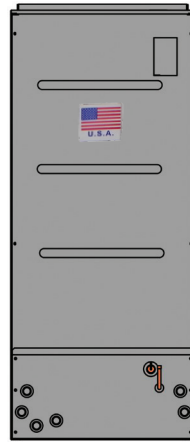

Up-Flow

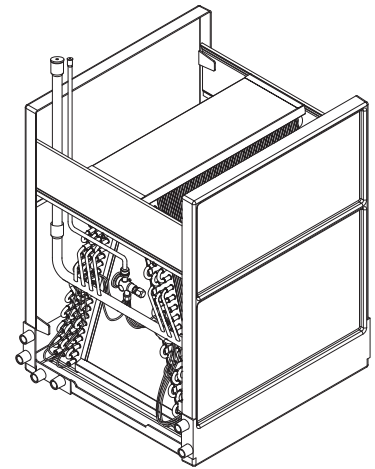

BLN Recommended Coil Sizes		
Air Handler		Tonnage
14 SEER BLN Air Handler with Coil		
BLN36-A38Y6G	14 SEER	3
BLN42-A30Y6G	14 SEER	3.5
BLN48-A3YY6G	14 SEER	4
BLN60-A3SY6G	14 SEER	5
Replacement Non-Rated BLN Air Handler with Coil		
BLN36-A38Y4G	Non-Rated	3
BLN42-A30Y4G	Non-Rated	3.5
BLN48-A3YY4G	Non-Rated	4
BLN60-A3SY4G	Non-Rated	5
<i>Freight Included on Pricing for Truckload Quantities</i>		



AllStyle

Coil Company, L.P