

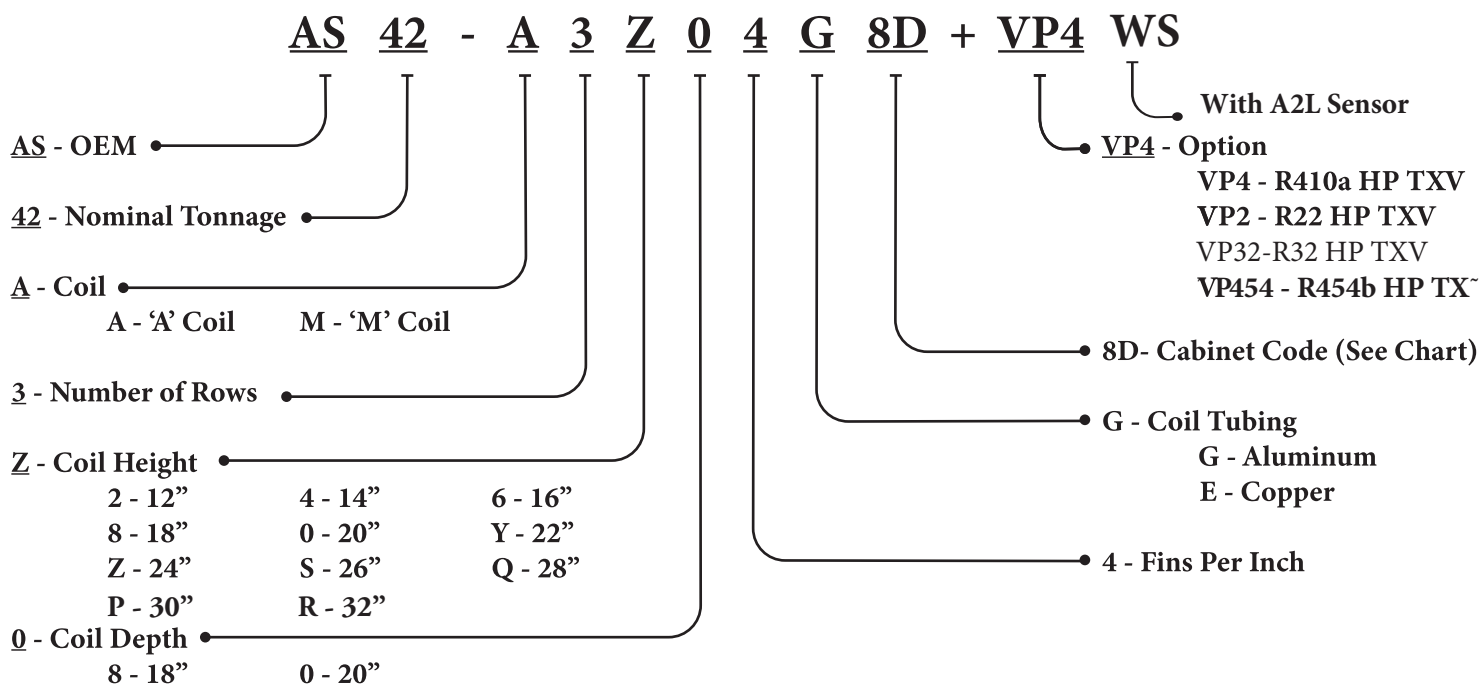

Cased Vertical Coils “AS” ‘A’ & ‘M’ Cabinet Sits on Furnace Draw-Through



Cabinet Code	Cabinet Height Based on Coil Size				Cabinet Width
	14" - 16"	18" - 20"	22" - 24"	26" - 30"	
5	21.25"	25.25"	---	---	14.50"
6	21.25"	25.25"	28.75"	32.625"	16.50"
7	21.25"	25.25"	28.75"	32.625"	17.50"
8	---	25.25"	28.75"	32.625"	21.50"
8D	---	25.25"	28.75"	32.625"	21.50"
9	---	---	28.75"	32.625"	24.50"
9D	---	---	28.75"	32.625"	24.50"

***RP29004- R32/R454b Sensor Kit**

Cased coils have the option of extended warranty if matched with a rated system, and refrigerant ports.
5 Cabinets have one horizontal drain pan - 6 - 9D Cabinets have two drain pans.