

GENERAL

The AB* Series is designed for horizontal recessed installations in a furred down area, above a suspended ceiling or recessed in the ceiling. AB*Series models are for electric heat, DX cooling, and for heat pump applications. The unit can be configured for return air flow through the integral access panel or at the end of the unit. Installation tabs are built into the cabinet to facilitate mounting the unit. Optional panels are available that allow a wide range of installation options. Electric resistance heaters are available along with optional air conditioning and heat pump indoor coils. Full service of all components is easily accomplished through the access panels.

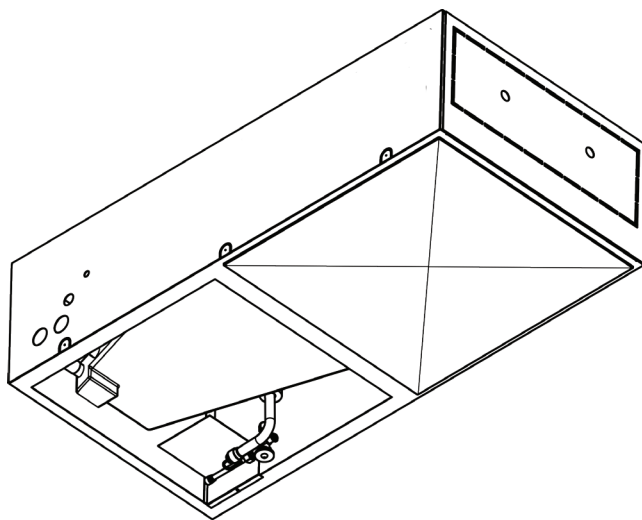

⚠ WARNING: Do not operate this unit unless all service panels/access doors are in place. If unit is located in the same area as the water heater or boiler, then the return air must be ducted to the unit. Seal all service entrances to the unit to prevent combustible byproducts from the water or boiler entering the air stream.

Installation of this unit shall be made in accordance with the National Electric Code, NFPA No. 90A and 90B, and any other local codes or utilities requirements.

⚠ WARNING: Due to possible damage to equipment or personal injury, installation, service and maintenance should be performed by a qualified technician. Consumer service is recommended only for filter replacement.

⚠ WARNING: Ensure all power is disconnected before installing or servicing this unit. More than one disconnect device may be required to de-energize the equipment. Hazardous voltage can cause severe personal injury. Make certain all panels are in place before operating this unit.

UNPACKING

Carefully unpack the unit and inspect the contents for damage. If any damage is found at the time of delivery, proper notification and claims should be made with the carrier who delivered the unit.

Check the unit rating plate to ensure model number and voltage, plus any kits agree with what you ordered. The manufacturer should be notified immediately of any discrepancy of parts or shortage.

LOCATION

The blower coil unit should be centrally located and may be installed in an attic, basement, or crawlspace with 0" clearance from any side, front, rear, or duct work. The unit must be installed in a level position to ensure proper condensation drainage. Make sure the unit is level in both directions within 1/8".

The unit incorporates installation tabs that mount to the framing and provide a 1/2" flange to trim to the finished

INSTALLATION GUIDE

edge of a sheet rock ceiling. The face panel mounts to the cabinet and trims the installation.

All service entrances and exits on the cabinet are recessed to allow for 2" x 4" framing of the opening. Any modifications to existing frame should be accomplished by the general contractor to ensure structural strength is maintained in the structure.

The structural opening in the framing should be 48" long and 24" wide. The unit should be positioned where the bottom edge of the cabinet is 1/2" below the framing member.

DUCT WORK

The duct work should be installed in accordance with the NFPA No. 90A "Installation of Air Conditioning and Ventilating Systems" and NFPA No. 90B "Residential Type Warm Air Heating and Air Conditioning Installation".

The duct work should be insulated in accordance with the applicable requirements for the particular type installation as required by HUD, FHA, VA the Applicable Building Code, Local Utility or other governing body.

CONDENSATE DRAINS

The AB* air conditioning or heat pump coil is supplied with 3/4" primary and auxiliary condensate drains. Both drains must be trapped outside the unit and piped in accordance with applicable building codes. Do not reduce the drain line size less than connection size on the drain pan. Condensate should be piped to an open drain or to the outside. All drains must pitch downward away from the unit a minimum of 1/8" per foot of line to ensure proper drainage.

REFRIGERANT PIPING

Refrigerant piping external to the unit shall be sized in accordance with the instructions of the manufacturer of the outdoor equipment.

When units are recess mounted, make certain that the piping connections are pressure tested prior to the wall being closed.

METERING DEVICE

Optional air conditioning or heat pump coils are shipped with a check-flow piston installed which is designed for air conditioning or heat pump operation unless the unit is specifically ordered with the valve installed (this is indicated with '+V' or '+VP' in the model number of the unit. If your application requires the addition of a thermal expansion valve or check expansion valve then it is necessary to remove the piston from the distributor assembly and install the proper metering device. Be sure to follow the instructions in the kit to ensure proper installation.

WIRING

Consult all schematic and pictorial wiring diagrams of this unit and the outdoor equipment to determine compatibility of the wiring connections and to determine specific requirements.

All field wiring to the blower coils should be installed in accordance with the latest edition of the National Electric Code NFPA No. 70 and any local codes.

Check rating plate on unit for rated volts, minimum circuit ampacity and maximum over current protection. Supply circuit power wiring must be 75°C (167°F) minimum copper conductors only. Copper supply wires shall be sized to the National Electric Code or local code requirements, whichever is larger.

The unit is shipped wired for 115/120VAC or 208/230VAC, 60 Hz, 1 Phase Operation. If the unit is to be operated at 208VAC/60 Hz., then follow the instructions on the indoor unit wiring diagram to change the low voltage transformer to 208VAC Operation.

Be sure the unit is properly grounded.

Class 2 low voltage control wiring should not be run in conduit with power wiring and must be separated from power wiring, unless class 1 wire of proper voltage rating is used. Low voltage control wiring should be 18 AWG, color coded (105°C minimum). For lengths longer than 100ft., 16 AWG. wire should be used.

Make certain that separation of control wiring and power wiring has been maintained.

INSTALLATION GUIDE

THERMOSTAT

Select a thermostat that is commonly referred to as a single stage cooling with electric sub base. This stat will energize the fan on a demand for heat or cool.

Install the thermostat on an inside wall away from drafts, lights or other heat sources in a location that has good air circulation from the other rooms being controlled by the thermostat. The thermostat should be mounted 4' to 5' above the floor.

AIR FILTER

An air filter must be installed prior to the air entering the evaporator coil to protect the oil, blower, and other internal parts from excessive dirt and dust. If the unit installed with the face panel to serve as the return air grille, then the integral return air filter may be used. If a remote return air is required, then a solid face panel and filter grille is required. Ductwork should be installed to facilitate the return air entering the back of the return air section of the unit. The door must be securely fastened in place to ensure proper filtration of the return air. Change the filter every 30 days or as soon as dust or dirt appears on the filter.

BLOWER

This unit is supplied with a multi-speed motor with a direct drive blower wheel which can obtain various air flows. As an option a ECM motor is also available. This motor provides variable speeds at a constant torque. The unit is shipped with the blower connected for high speed. If a lower blower speed is required, disconnect all power to the unit, remove the black indoor fan motor lead from the fan relay, place an insulated cap on the black lead, remove the insulated cap from the red indoor fan motor lead, place a spade connector on the lead and connect it to the fan relay where the black lead was originally connected. Be sure to check the air flow and the temperature drop across the evaporator coil to ensure that you have sufficient air flow.

SEQUENCE OF OPERATION

Cooling (Cooling only or heat pump with reversing valve energized in heat mode): When the T-Stat calls for cooling, the circuit between R and G is complete, and the blower relay is energized. The N.O. contacts will close, which allows the indoor blower to operate. The circuit between R and Y is completed causing the contactor on the outdoor equipment to close, and start the compressor and the outdoor fan motor. The circuit between R and Y is completed causing the contactor on the outdoor equipment to close, and start the compressor and the outdoor fan motor.

Cooling (Heat pump with reversing valve energized in cooling mode): When the thermostat calls for cooling, the circuit between R and G and R and O is complete. Circuit R and O energizes the reversing valve to the cooling position. Circuit R and G energizes the blower relay. The N.O. contacts will close after a time delay then the indoor blower will operate. The circuit between R and Y is complete. Which causes the contactor on the outdoor equipment to close, and the start the compressor and the outdoor fan motor.

Heating (Electric heat only): When the thermostat calls for heat, the circuit between R and W is completed. The heat sequencer is energized. A time delay will occur, which allows the heating element(s) and the indoor blower motor to come on.

Heating (Heat pump reversing valve energized in the heat mode): When the thermostat calls for heat the circuits between R and B, R and Y and R and G are completed. Circuit R and B energize the reversing valve switching it to the heat position. Circuit R and Y energized the outdoor unit contactor starting the compressor and outdoor fan. Circuit R and G energizes the blower relay starting the blower motor.

If the indoor room temperature should continue to fall, circuit R and W2 is by the second-stage heat bulb on the thermostat. Circuit R-W2 energizes the heat sequencer. The complete circuit will energize the supplemental electric heat.

Blower Time Delay: This unit is equipped with timed on and a timed off relay. This relay delays the start and delay the stopping of the indoor fan motor to maximize the efficiency of the unit.

INSTALLATION GUIDE

Defrost. When the unit starts the defrost cycle supplemental heat can be provided by connecting B on the blower coil to the defrost relay on the outdoor heat pump. This will complete the circuit between R and B (in the blower coil) through a set of contacts in the defrost relay in the outdoor unit. This circuit when it is connected, will help prevent cold air from being discharged from the indoor unit during the defrost.

START-UP

Once all connections are complete the unit should be started up, and a check out of the completed system should be performed. Before performing any system test, make sure that all grilles, registers, and dampers are open and set to the correct position. Also make certain that the air filter is installed in the return air prior to running the air handler.

A performance test should be conducted in the accordance with the outdoor equipment manufacturer's instructions. Airflow tests should be conducted in the heating and cooling modes to ensure satisfactory operation.

MAINTENANCE

The system air filter(s) should be inspected, cleaned or replaced at least monthly. If the filter is mounted internal to unit, make sure that electrical power is disconnected before removing the access panels. Make certain the access panels are replaced and secured properly before placing the unit back in operation. This product is designed for dependable service, however periodic maintenance should be scheduled to be conducted by trained professional service personnel. This service should be conducted at least annually, and should include testing and inspection of electrical and refrigerant components. The heat transfer surface should be cleaned. The blower motor is permanently lubricated for normal operating conditions.

NOTE:

The condensate drain pan shown in Figure 1., has an adjustment strap to ensure proper condensate removal. The strap is identified by the arrow in the figures. If it is found to be necessary, the strap may be easily loosened and refastened to change the pitch in the drain pan toward the drain outlets. The drain pan pitch should not exceed 1/2". For proper drain line connections, follow instructions from "Condensate Drain".

Figure 1. Drain Pan Adjustment Strap

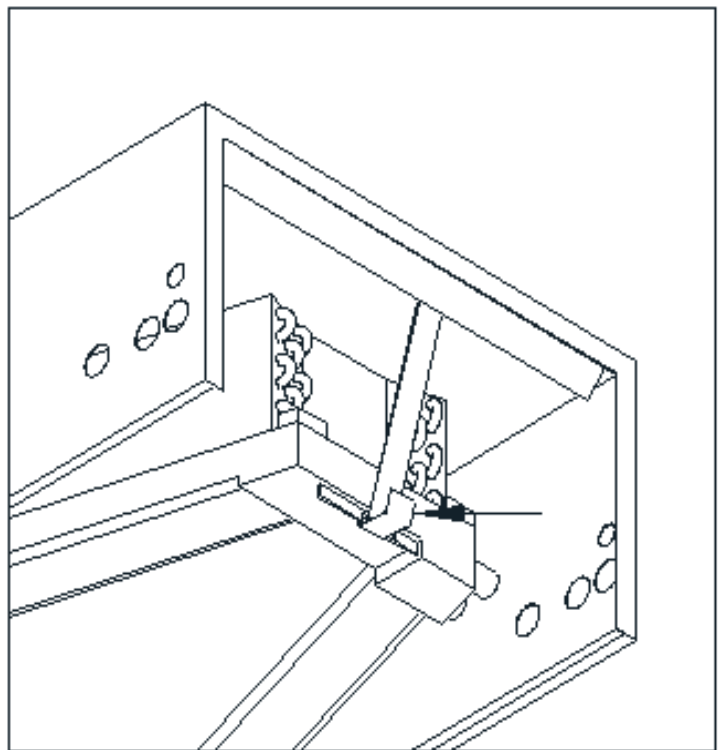

INSTALLATION GUIDE

WARNINGS

Do not store or use any corrosives or combustibles in the vicinity of this unit. All panels must be in place and properly secured before operating this equipment.

All electrical power servicing this unit must be disconnected prior to removal of any panels. Service of this unit must be accomplished by qualified trained professional personnel only.

This unit is manufactured in the USA by:



WIRING DIAGRAM

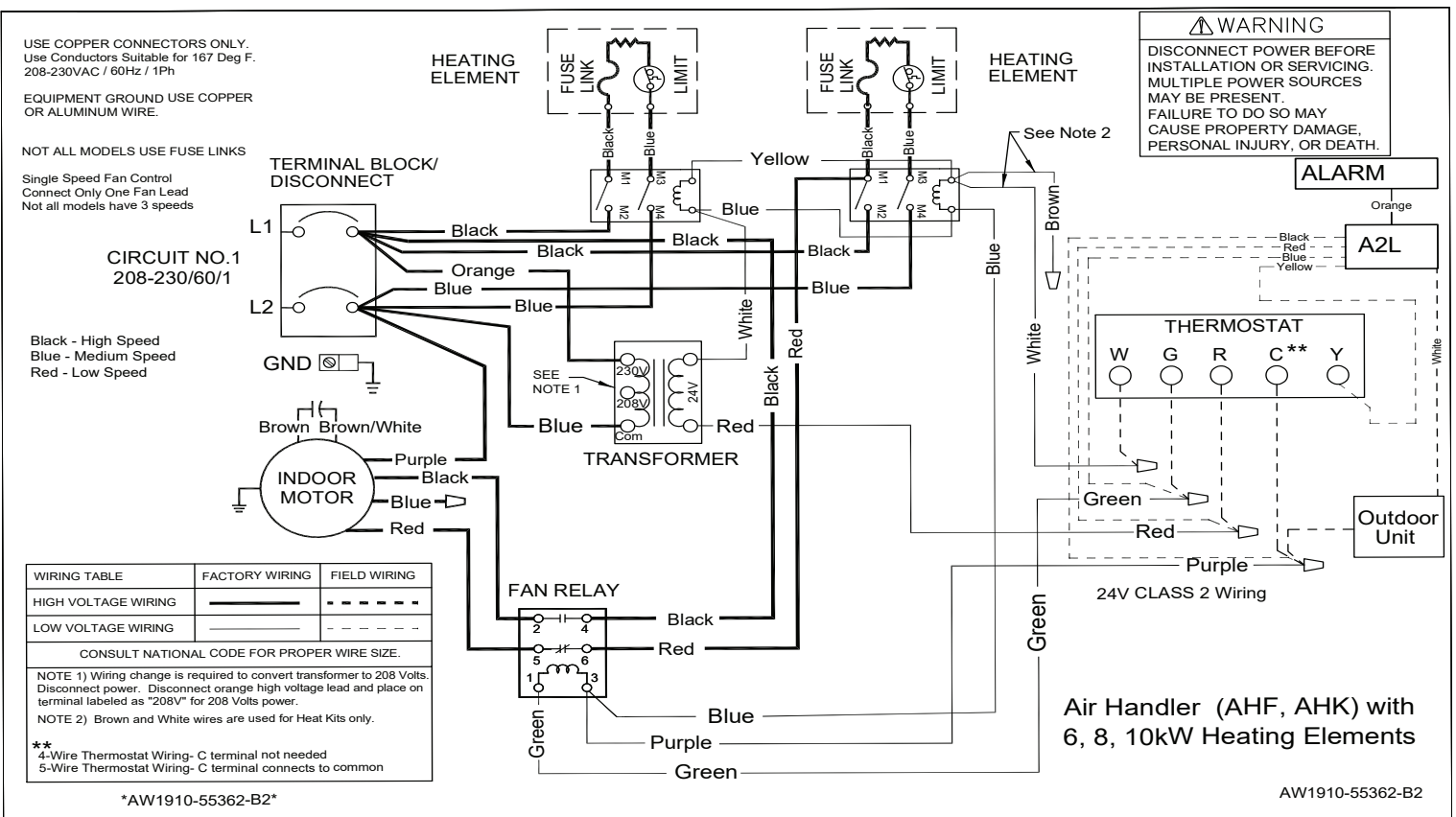
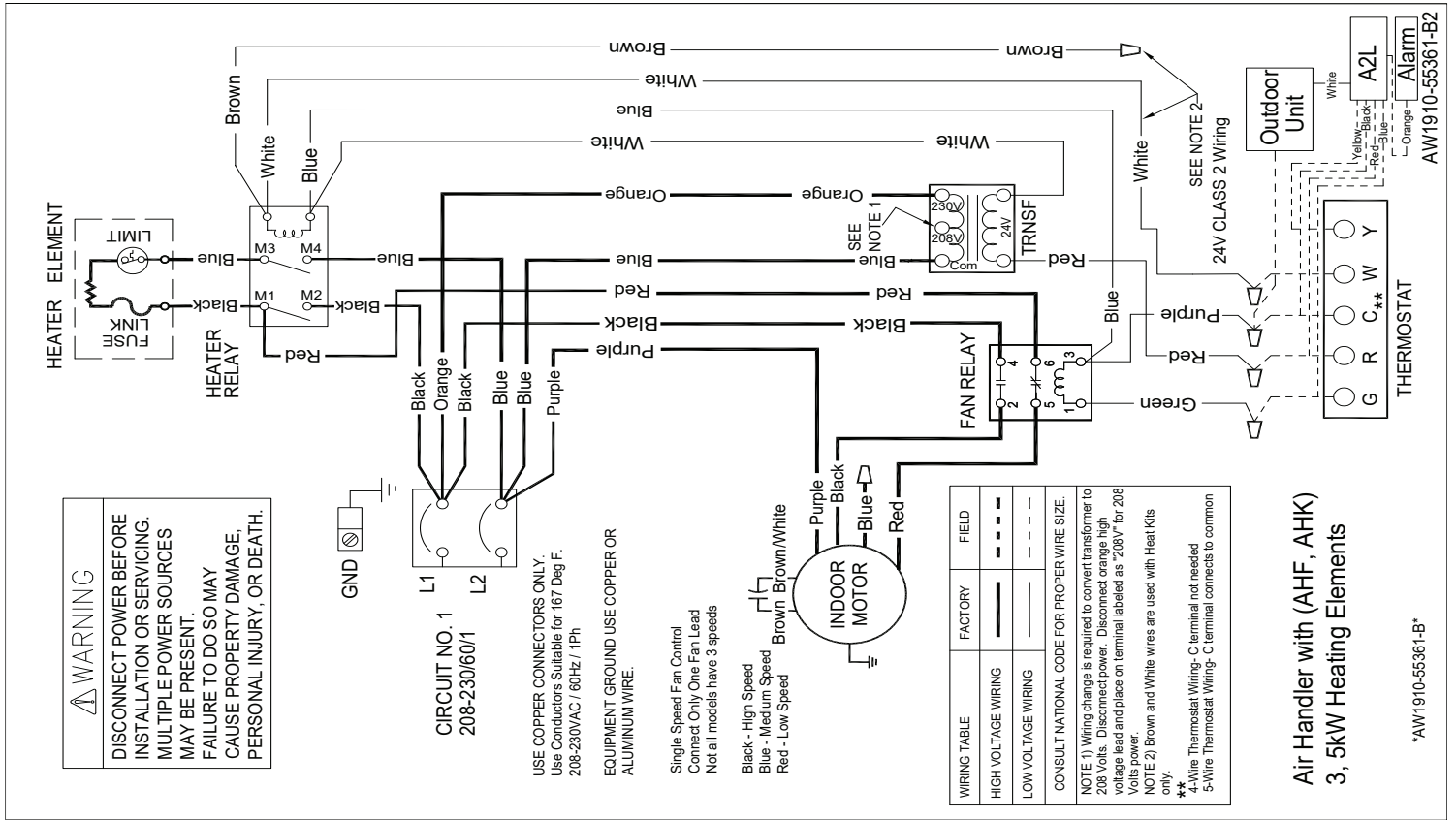

WIRING DIAGRAM

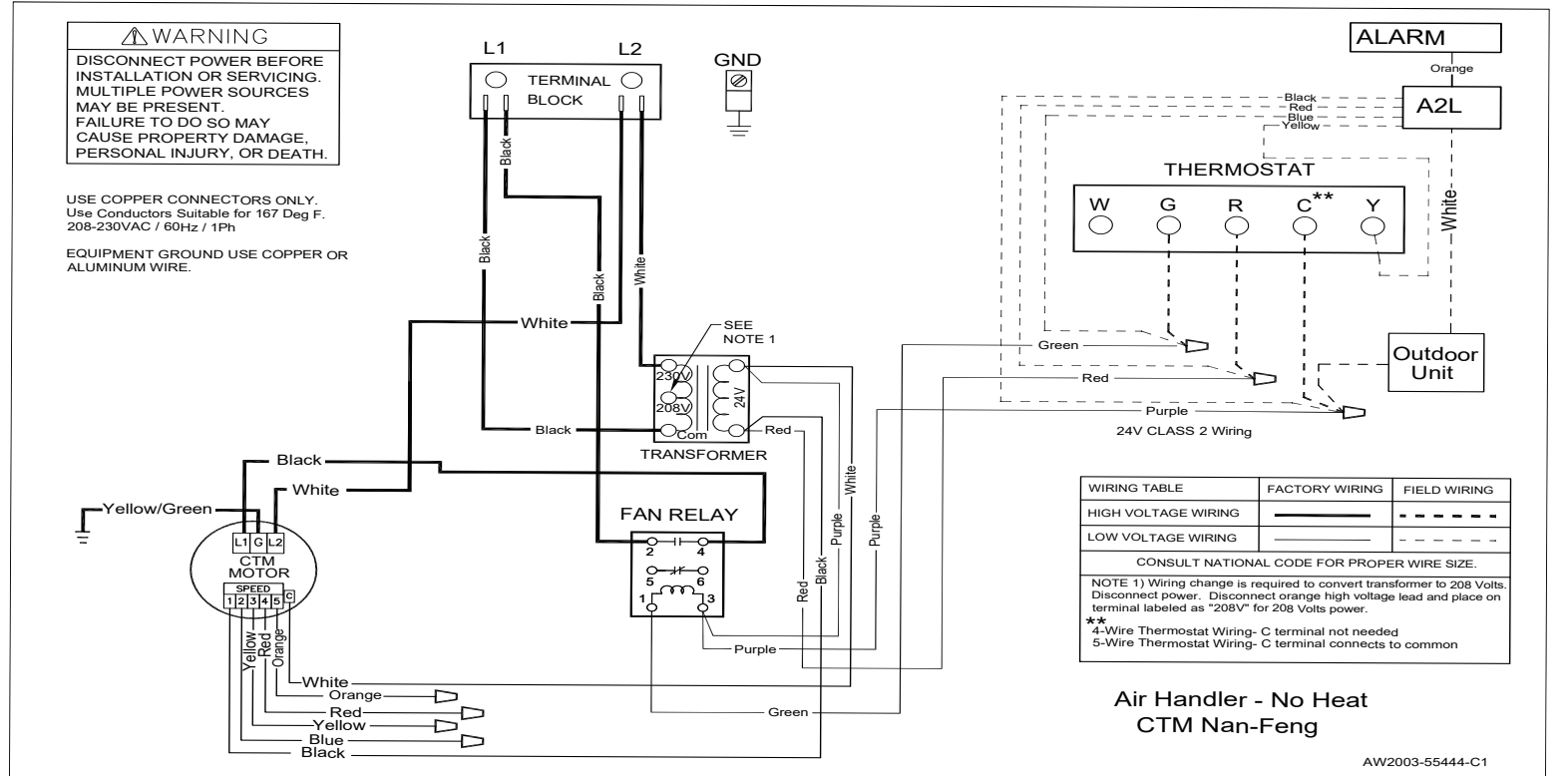
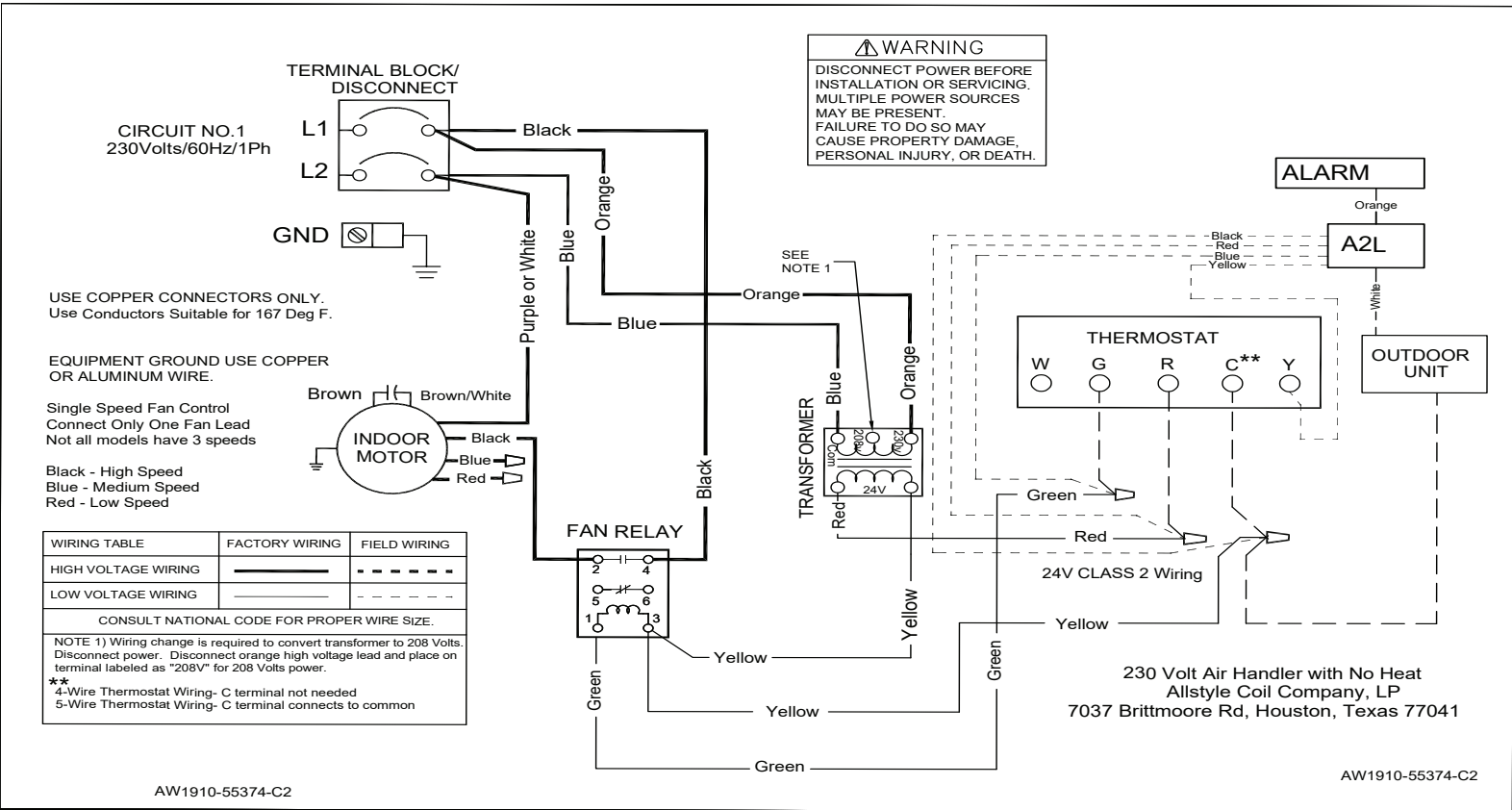

WIRING DIAGRAM

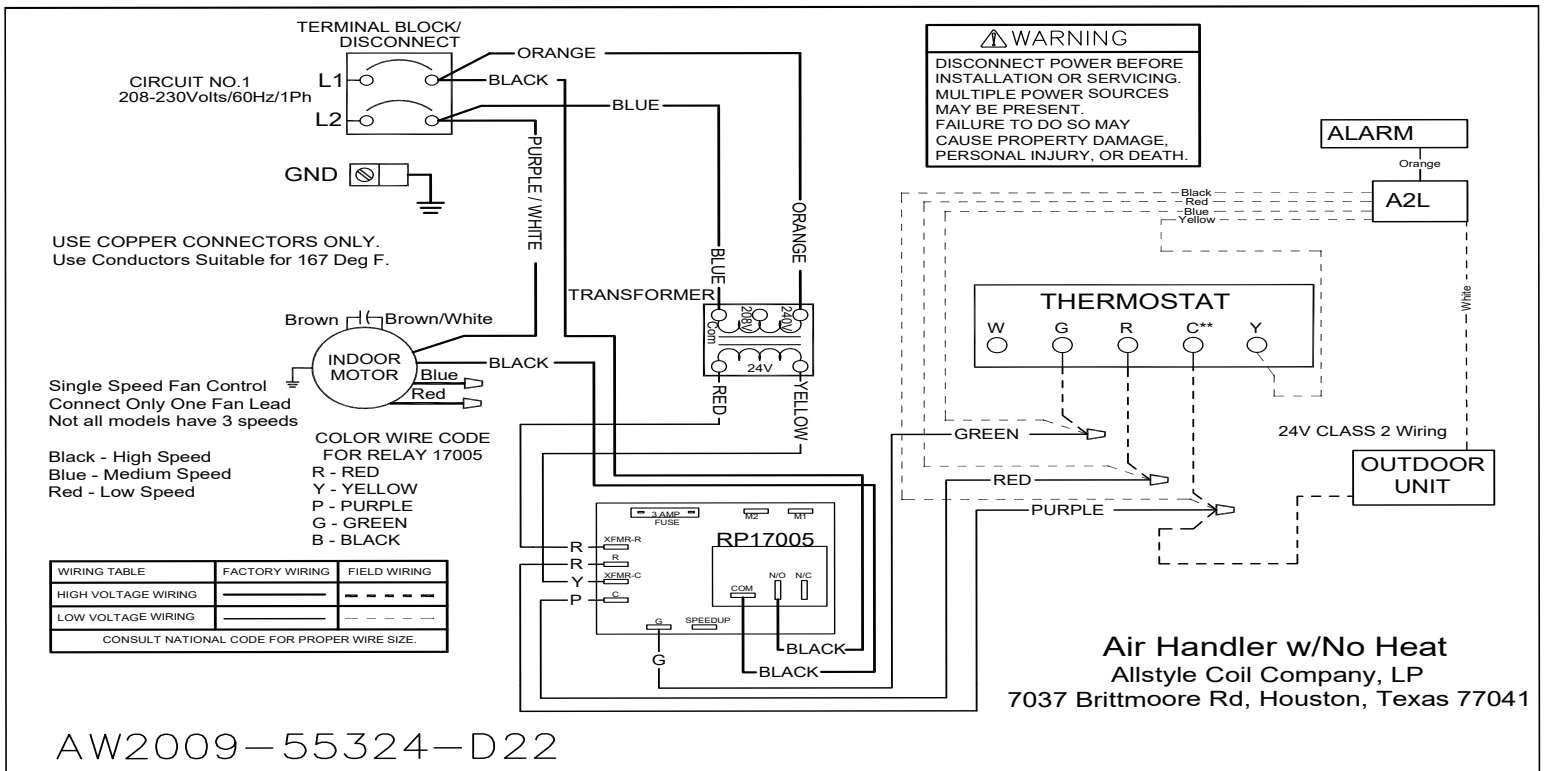
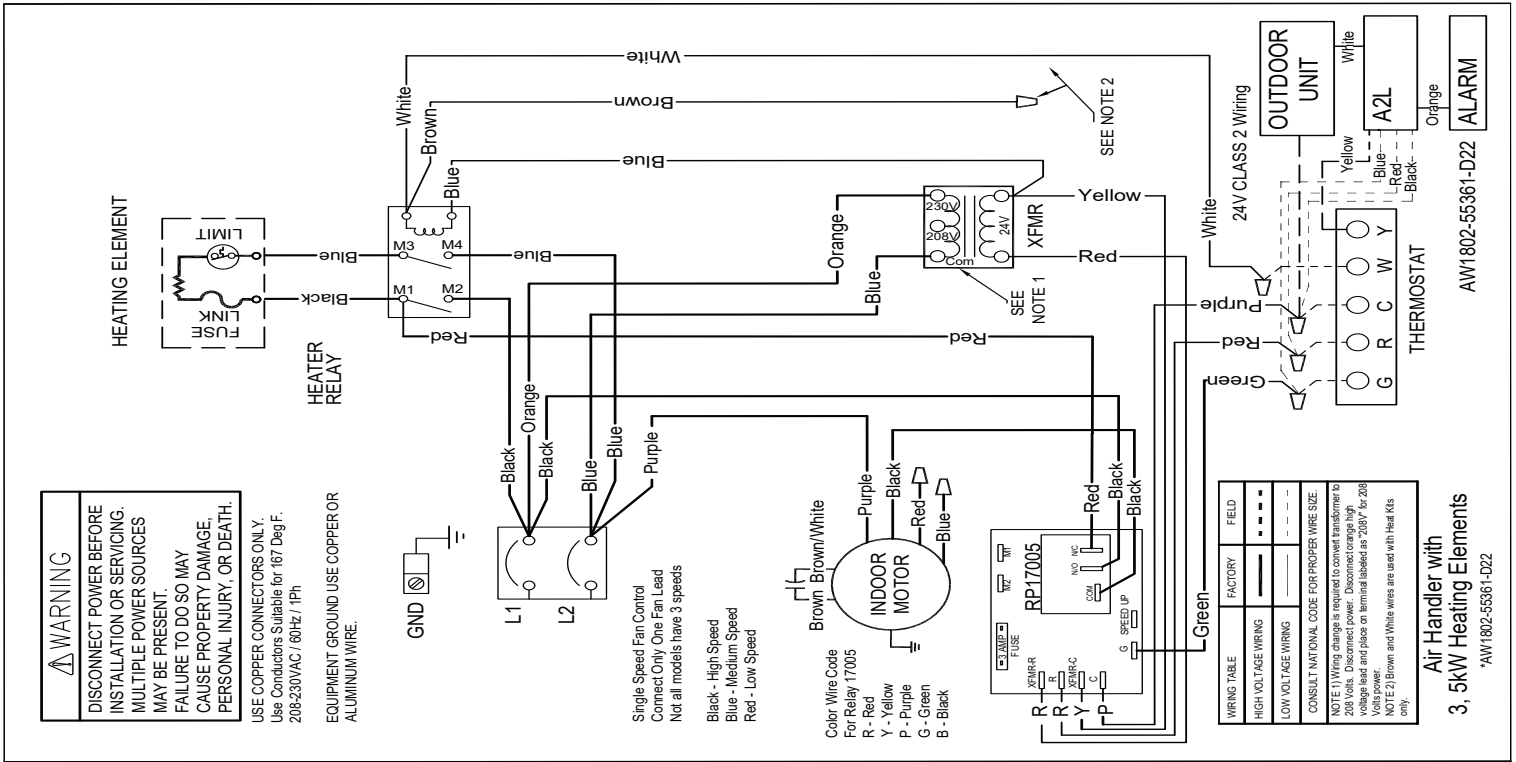

AW2009-55324-D22

WIRING DIAGRAM

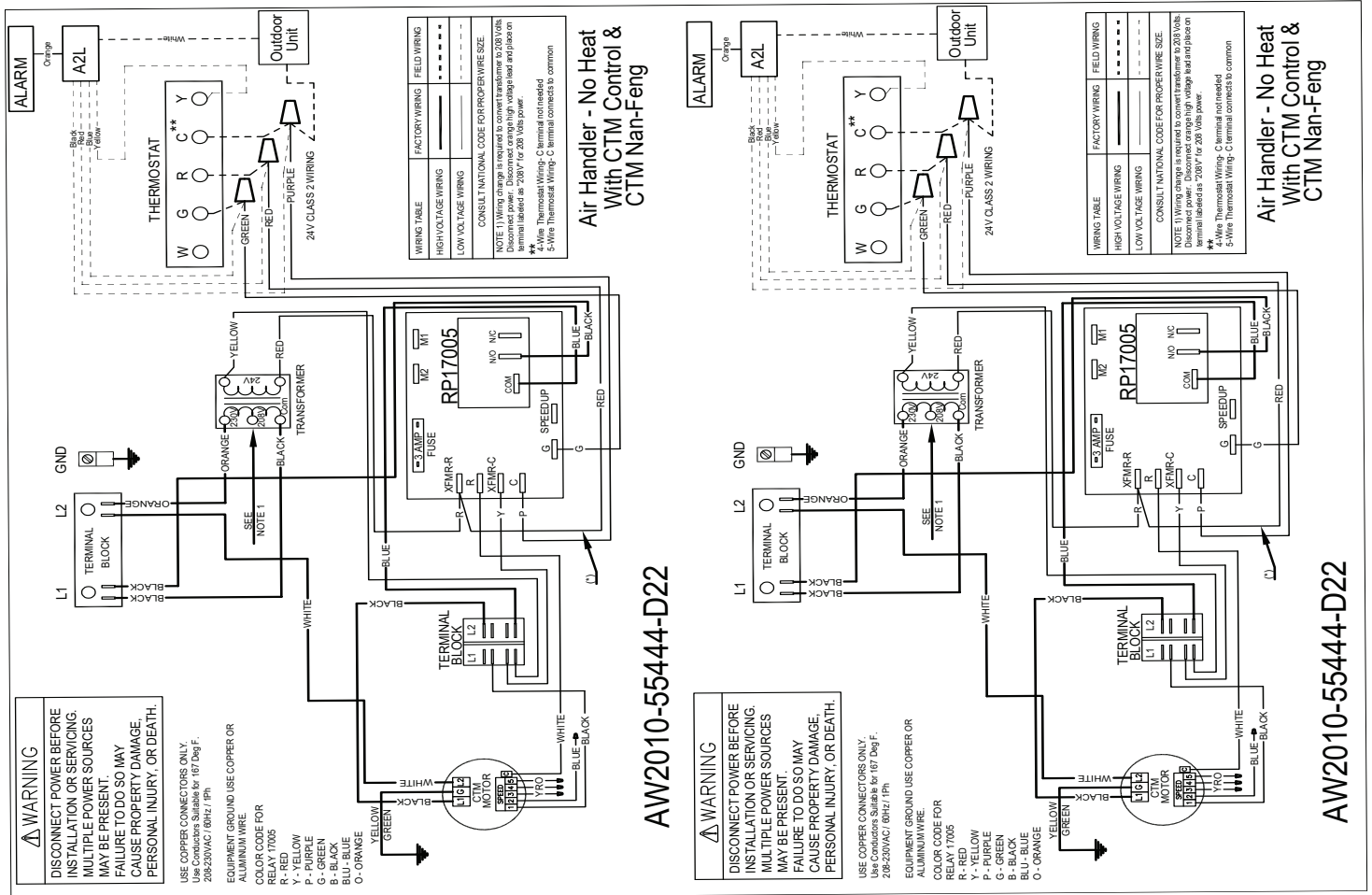
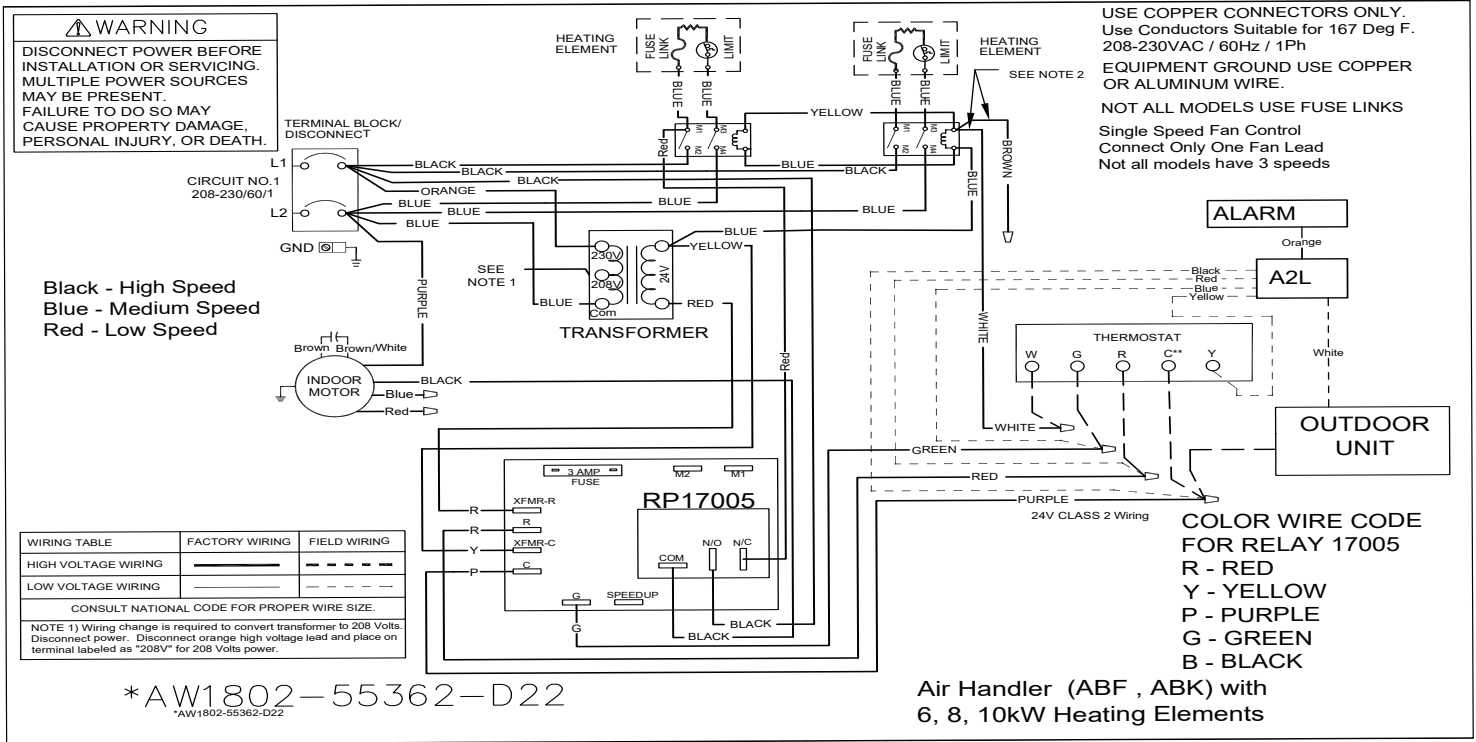

⚠ WARNING
 DISCONNECT POWER BEFORE INSTALLATION OR SERVICING. MULTIPLE POWER SOURCES MAY BE PRESENT. FAILURE TO DO SO MAY CAUSE PROPERTY DAMAGE, PERSONAL INJURY, OR DEATH.

USE COPPER CONNECTORS ONLY. Use Conductors Suitable for 167 Deg F. 208-230VAC / 60Hz / 1Ph

EQUIPMENT GROUND USE COPPER OR ALUMINUM WIRE.

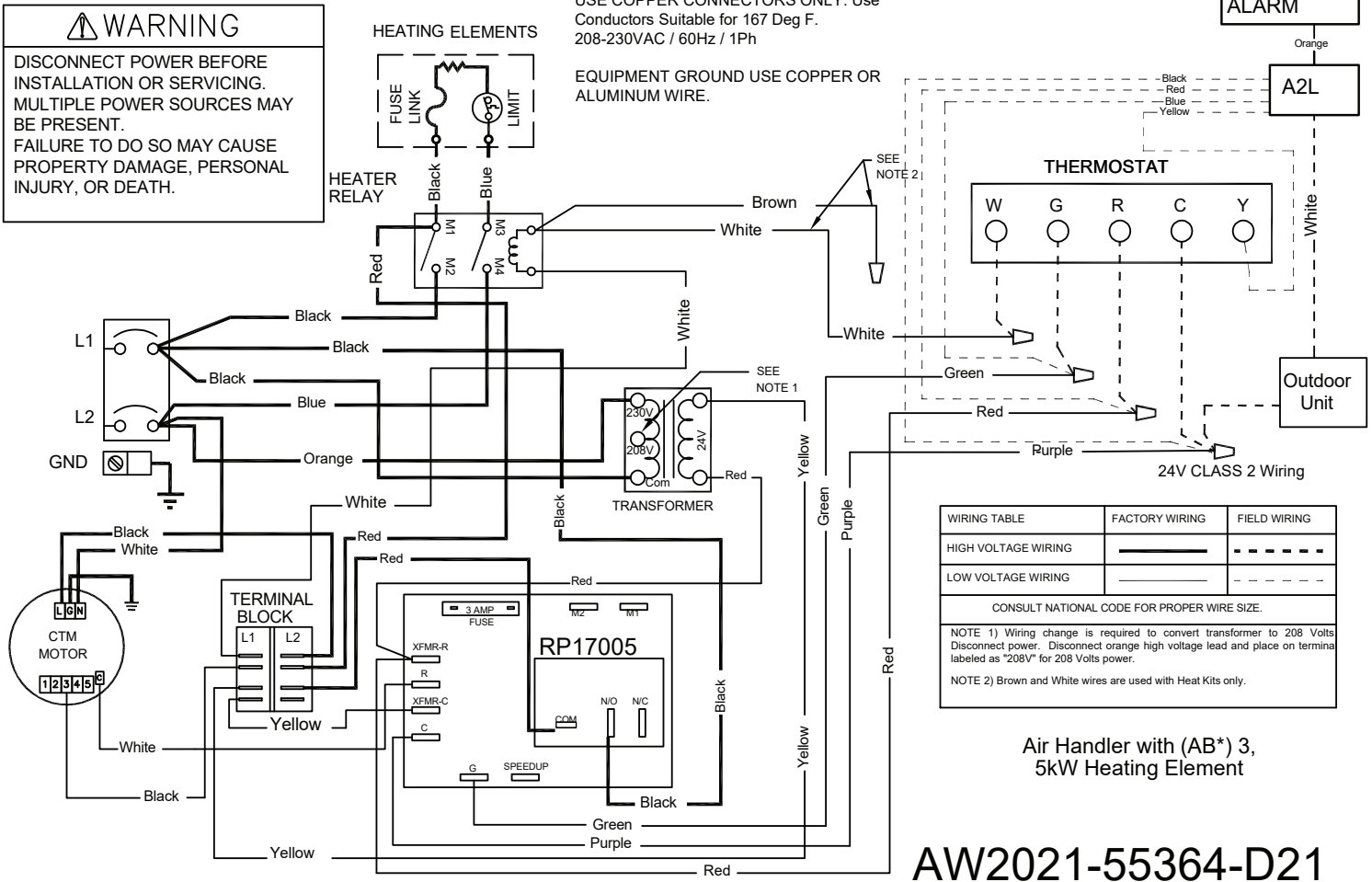

USE COPPER CONNECTORS ONLY. Use Conductors Suitable for 167 Deg F. 208-230VAC / 60Hz / 1Ph

EQUIPMENT GROUND USE COPPER OR ALUMINUM WIRE.

NOT ALL MODELS USE FUSE LINKS

Single Speed Fan Control
 Connect Only One Fan Lead
 Not all models have 3 speeds

CIRCUIT NO.1
 208-230/60/1

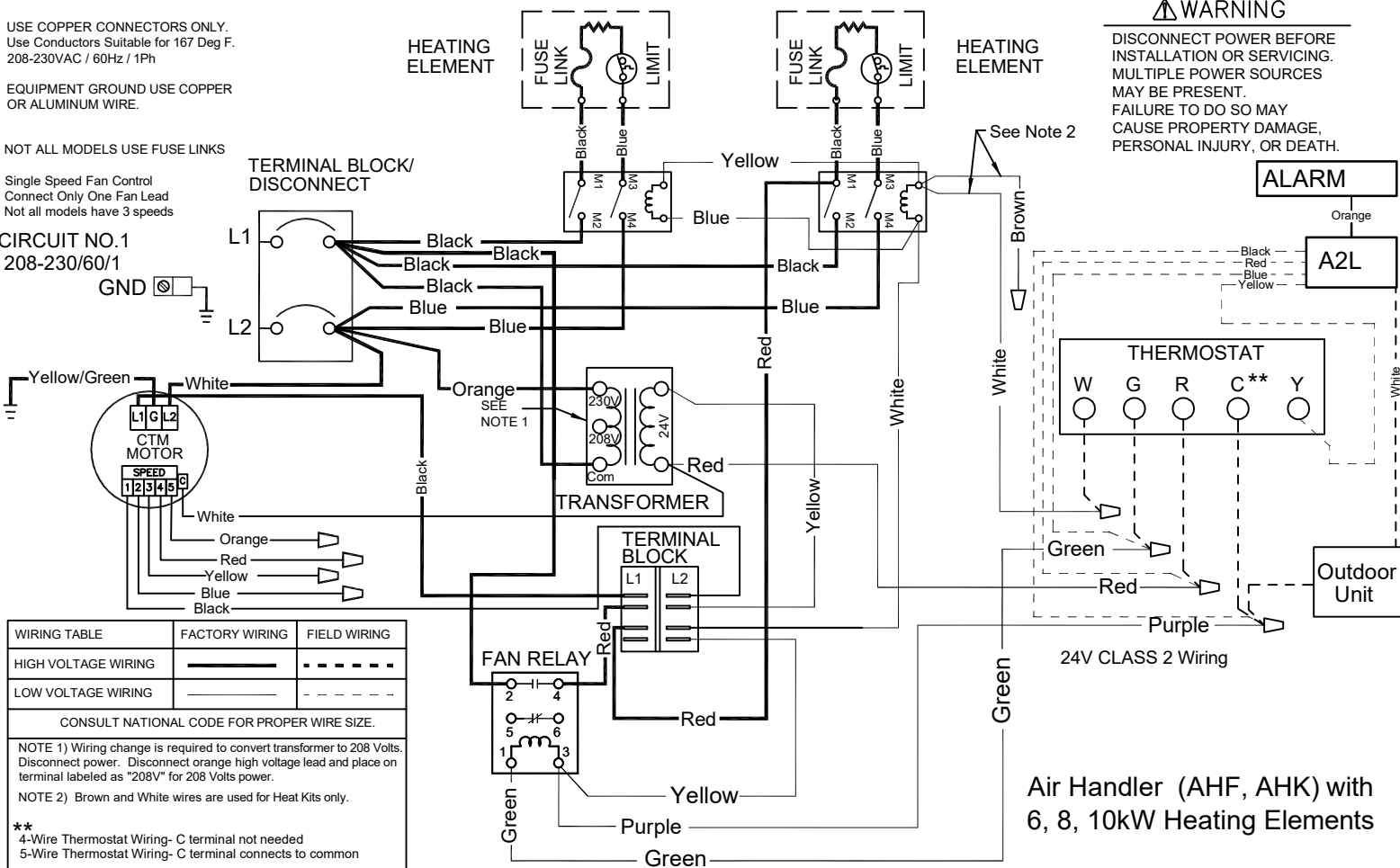

WARNING
 DISCONNECT POWER BEFORE
 INSTALLATION OR SERVICING.
 MULTIPLE POWER SOURCES MAY BE
 PRESENT.
 FAILURE TO DO SO MAY CAUSE
 PROPERTY DAMAGE, PERSONAL
 INJURY, OR DEATH.

USE COPPER CONNECTORS ONLY. Use
 Conductors Suitable for 167 Deg F, 120VAC / 60Hz /
 1Ph

EQUIPMENT GROUND USE COPPER OR
 ALUMINUM WIRE.

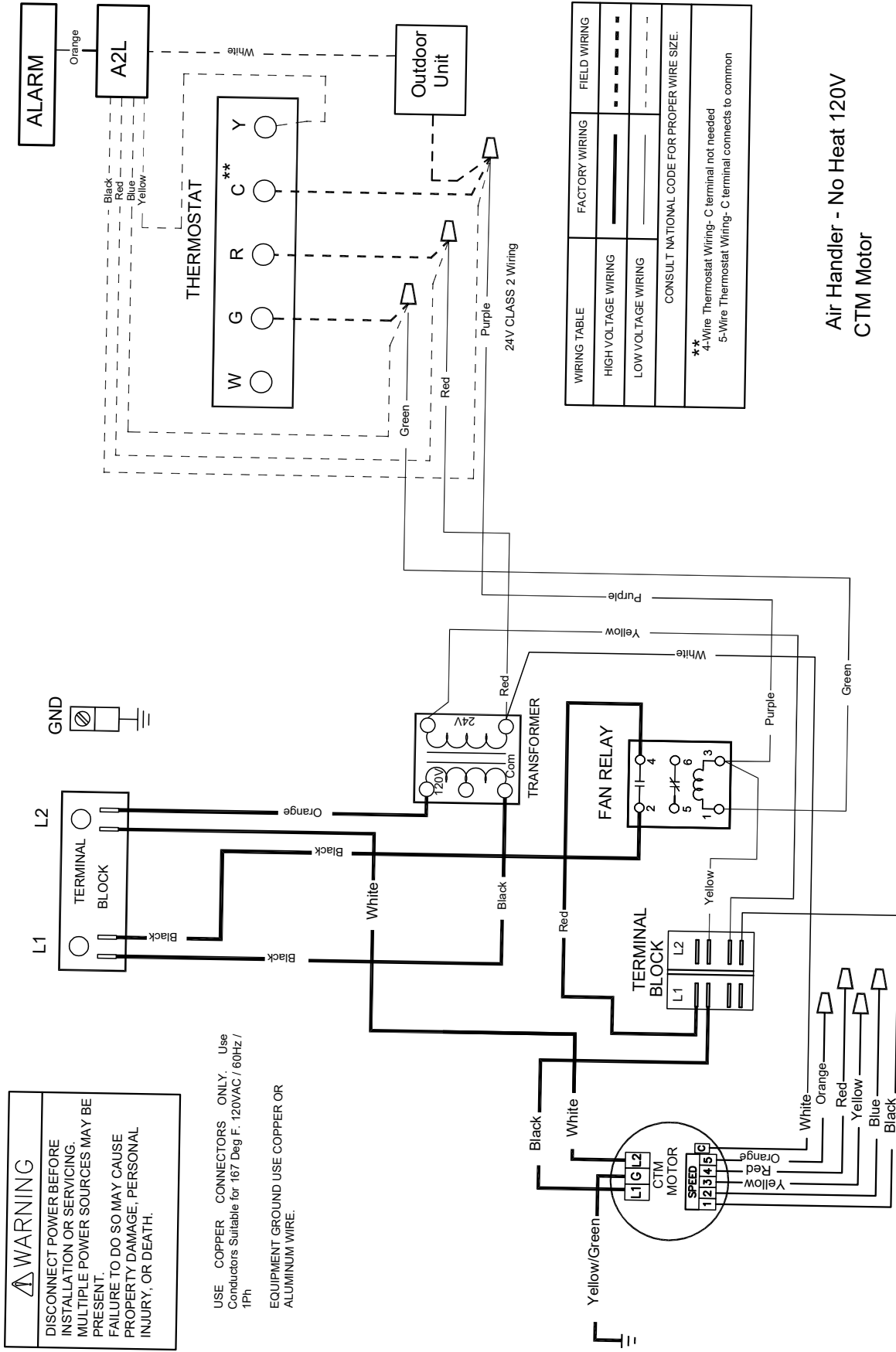

**Air Handler - No Heat 120V
 CTM Motor**



4.2026